

# Single Stage Horizontal Type Sewage and Wastewater Pumps

---

## ENDURO-PRO SERIES

---



## TECHNICAL MANUAL



# ENDURO-PRO Series

## Single Stage Horizontal Type Sewage and Wastewater Pumps



Mas Grup

### GENERAL SPECIFICATION

#### Fields of Application

- Water treatment plants
- Flooded water transfer
- Liquids containing sludge, fibrous and solid particles
- Domestic and industry sewage
- Activated sludge

#### Pumped Liquids

Clean water, non-corrosive and non-flammable liquids, wastewater, sewage, liquids containing fibrous particles, domestic wastewater, and wastewater treatment plants, flood waters, biological fluids, fluids containing solid.

Please contact MAS DAF MAKINA SANAYI A.Ş. for special applications.

#### Design

- Thanks to a special impeller designs this series is used different fields and different kinds of waste can be pump depending on the impeller structure.
- Our pumps are produced with modern casting and manufacturing technology can be made of different materials according to their application areas and customer demand.
- Thanks to back pull out design, the rotating parts of the pump are provided to change for maintenance and repair without removing suction and discharge line.
- Various assembly option are possible- mono block, coupling, belt driven and vertical assembly.
- Different accessory options are available to extend mobility and protection of the pump- Stationery Cabinet System, mobile Cabinet System and trailer assembly options.
- Discharge flanges can be redirected to the left, right or up thanks to the removable supporting foot.

#### Shaft

The pumps are provided with the rigid shaft capable of supporting different loading conditions. Since the shaft diameter is highly resistant to bending and the distance between the bearing and the sealing is short, pump can operate at optimal conditions for the sealing.

#### Bearings

Lifelong oil lubricated bearings are used in ENDURO-PRO series pumps. Alternatively, grease lubricated bearings are used. On pump and motor side 3300/6300 series heavy duty bearings can be used.

#### Shaft Seal

##### Special Stuffing Box Design\*

Spiral grooves in the big conical seal chamber avoid contamination of the sealing environment with solids improved mechanical seal life.

*\*Available on some models.*

In standard production, SiC-SiC mechanical seals are used for sealing. 2nd seal region is protected by a buffer oil region, can provide superior protection in case of leakage.

#### Technical Data

- Discharge Flanges DN 50 – DN 300
- Impeller Diameter  $\varnothing 140 - \varnothing 430$  mm
- Q 20-1500 m<sup>3</sup>/h
- Hm 10-50 m
- Speed Up to 3600 RPM
- Operating Pressure 10 bar

#### Driver

TEFC (Totally Enclosed Fan Cooled) 3 phase, squirrel caged, in accordance to DIN 42673, IM 2001B35 type, high efficiency IE2 or IE3 (optional) class electrical motor or diesel engine which complies with DIN, IEC and VDE is used to drive the pump in proper speed and power.

#### Identification Code for Pump

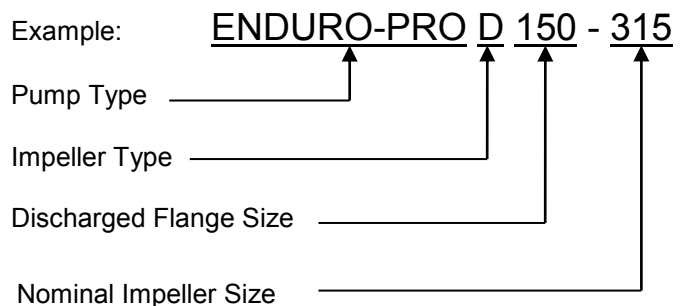

# ENDURO-PRO Series

## Single Stage Horizontal Type Sewage and Wastewater Pumps

---



Mas Grup

### Impeller Types

---

#### X Type Vortex Impellers

In this type of impellers, liquid transfer is provided by vortex movement in front of impeller. Liquids are supplied transmission to the discharge flange by reducing contact the impeller. These types of impellers are suitable for pumping liquids containing long fibers (hair, thread, etc.), small solid particles and having a certain rate gaseous or air.

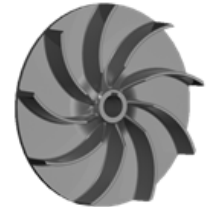

- Raw Sewage
- Activated Sludge
- Circulated and Heated Sludge
- Wastewater Containing Hair, Thread etc.

#### S Type Single Vane Impellers

These types of impellers for liquids containing long fibers, big solid particles (close to the diameter of the pump intake).

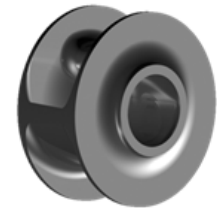

- Raw Sewage
- Solid - Liquid Mixtures
- Raw and Digested Sludge
- Activated Sludge
- Circulated and Heated Sludge

#### D Type Double Vane Impellers

These types of impellers for liquids containing up to certain size sludge and solid particles but not containing fiber, gaseous or air. Its symmetrical design provides balanced operation without vibration.

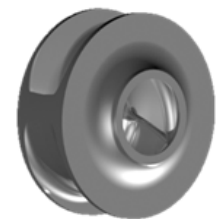

- Grilled Sewage
- Mechanically Purified Sewage
- Industrial Wastewater
- Activated Sludge
- Floodwaters

#### D Type Semi-Open Impellers (for DN50)

These types of impellers, which mounted on the pump DN50 dimensions, for liquids containing up to certain size sludge and solid particles but not containing fiber, gaseous or air. This impeller design is ensured that solid particles not clogged during delivery of the waste water.

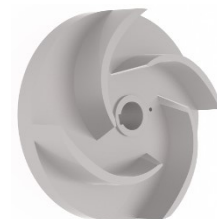

- Grilled Sewage
- Mechanically Purified Sewage
- Industrial Wastewater
- Activated Sludge
- Floodwaters

# ENDURO-PRO Series

Single Stage Horizontal Type Sewage and Wastewater Pumps



Mas Grup

## Sectional Drawing and Part List

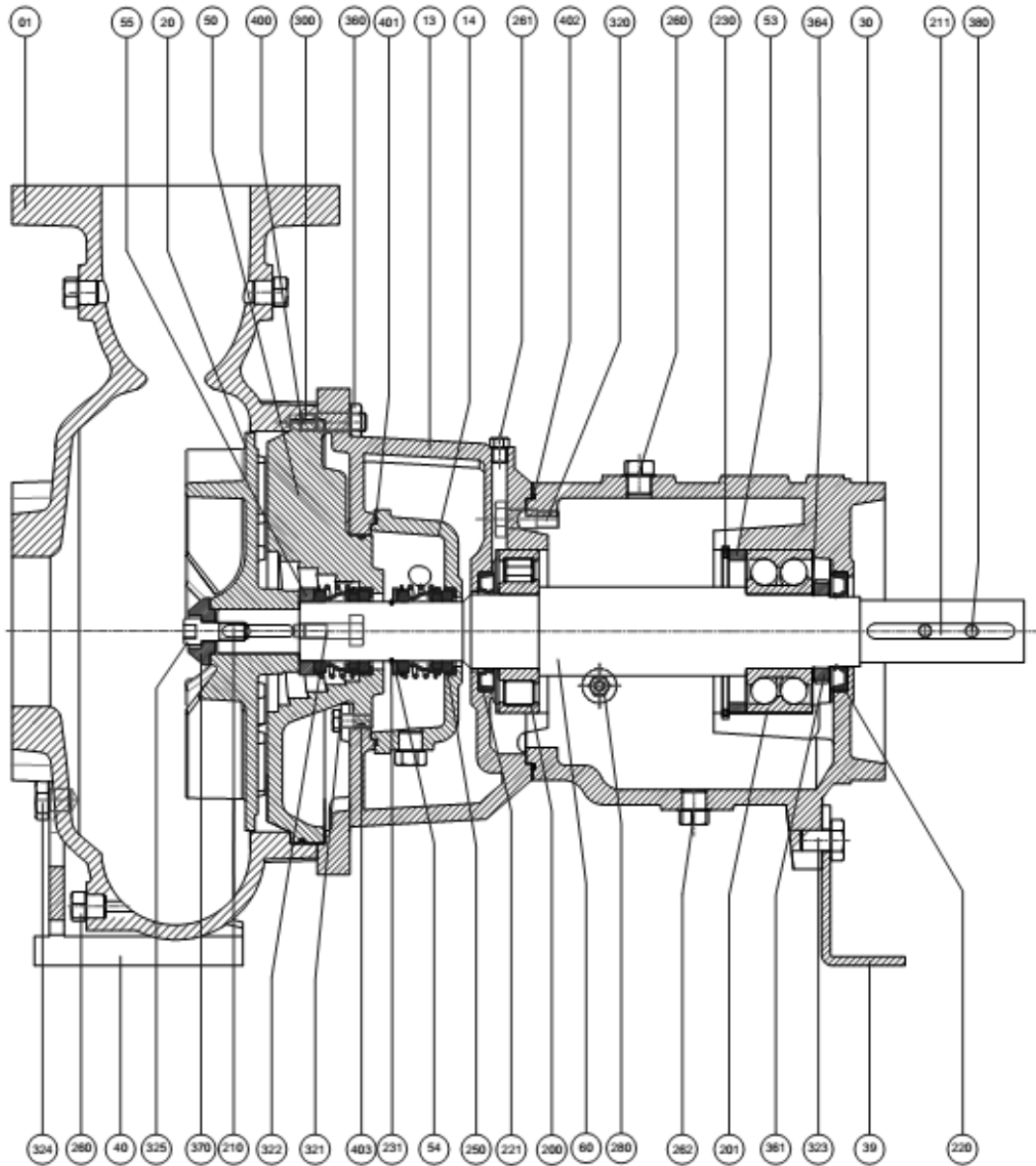

PART NO	PART NAME	PART NO	PART NAME	PART NO	PART NAME
01	Volute Casing	210	Impeller Key	322	Bolt
13	Spacer	211	Key	323	Bolt
14	Sealing Oil Bath	220	Oil Seal	324	Bolt
20	Impeller	221	Oil Seal	325	Imbues Bolt
30	Bearing Housing	230	Retaining Ring	360	Nut
39	Supporting Pedestal	231	Retaining Ring	361	Nut
40	Supporting Foot	250	Mechanical Seal	364	Safety Sheet
50	Stuffing Box	260	Plug	370	Impeller Washer
53	Bearing Sleeve	261	Plug	380	Setscrew
54	Mechanical Seal Sleeve	262	Plug	400	O-Ring
55	Mechanical Seal Sleeve	280	Oil Gauge	401	O-Ring
60	Shaft	300	Stud	402	O-Ring
200	Bearing	320	Bolt	403	O-Ring
201	Bearing	321	Bolt		

## ENDURO-PRO Series

Single Stage Horizontal Type Sewage and Wastewater Pumps



Mas Grup

### Material Specifications

PART	MATERIAL
Motor Casing	Cast Iron (GG25)
Pump Casing	Cast Iron (GG25)
Impeller	Cast Iron (GG25)
Wear Ring	Stainless Steel (AISI 304-316)
Shaft	Stainless Steel (AISI 420)
Mechanical Seal	SiC-SiC (TS EN 12756)

*\*Different material options are available upon request.*

### Material Equivalent

Description	DIN 17007	EN-DIN	ASTM
Cast Iron	0.6025	GJL-250 (GG25)	A 48 Class 40-B
Nodular Cast Iron	0.7040	GJS-400-15 (GGG40)	A 536 Gr.60-40-18
Cast Bronze	2.1050.01	G-Cu Sn 10	B 584 C 90700
Chrome Steel	1.4021	X20 Cr 13	A 276 Type 420
Chrome Nickel Steel	1.4301	X5 Cr Ni 18.9	A 276 Type 304
Chrome Nickel Molybdenum Steel	1.4401	X5 Cr Ni Mo 18.10	A 276 Type 316

# ENDURO-PRO Series

Single Stage Horizontal Type Sewage and Wastewater Pumps

## Round Flange Sizes

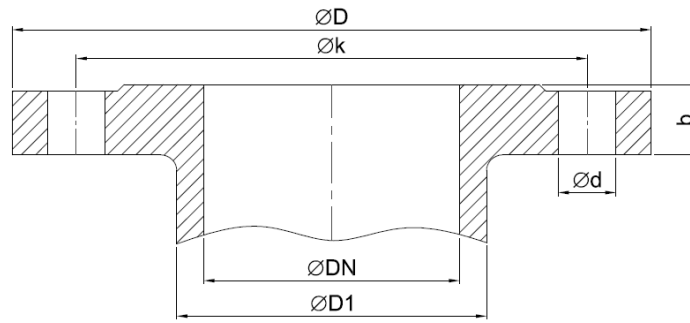

PIPE		FLANGE			BOLTS		
NOMINAL SIZE (mm)	OUTER DIAMETER (mm)	DIAMETER (mm)	NOMINAL SIZE (mm)	OUTER DIAMETER (mm)	QUANTITY	NOMINAL SIZE (mm)	HOLE DIAMETER (mm)
DN	D1	D	b	k	z	M	d
80	97	200	22	160	4	M 16	18
100	118	220	22	180	8	M 16	18
150	170	285	24	240	8	M 20	23
300	326	445	28	400	12	M 20	23

## General Sizes

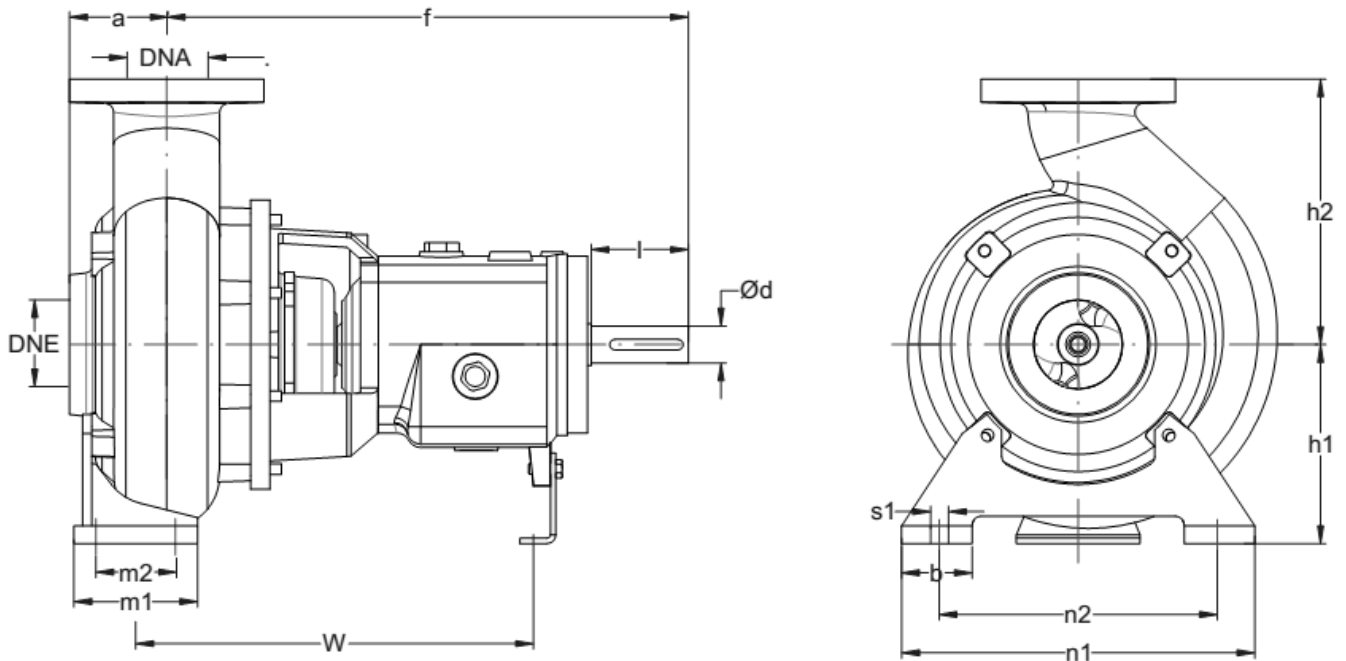

Pump Type	DNE	DNA	ød	a	f	l	W	b	s1	m1	m2	n1	n2	h1	h2
80-250	80	80	42	83	560	110	425	80	16	140	75	400	315	225	282
100-250	100	100	42	110	570	110	450	80	16	140	75	400	315	275	300
100-315	100	100	42	130	715	95	540	80	18	180	110	470	400	300	355
150-315	150	150	42	130	715	95	540	80	18	180	110	470	400	300	355
300-315	300	300	45	275	730	110	575	146	30	240	180	620	500	355	600

# ENDURO-PRO Series

Single Stage Horizontal Type Sewage and Wastewater Pumps



Mas Grup

## ENDURO-PRO SERIES WITH SELF PRIMING SYSTEM

Castanets system that is not affected by solid particles, not congested due to its dynamic structure and closes the vacuum line when the inside of the body is filled with fluid

Vacuum-resistant spiral wire hose connecting the suction line with the vacuum system

Vacuum system providing vacuum affect consistently with double pumps and timing belt

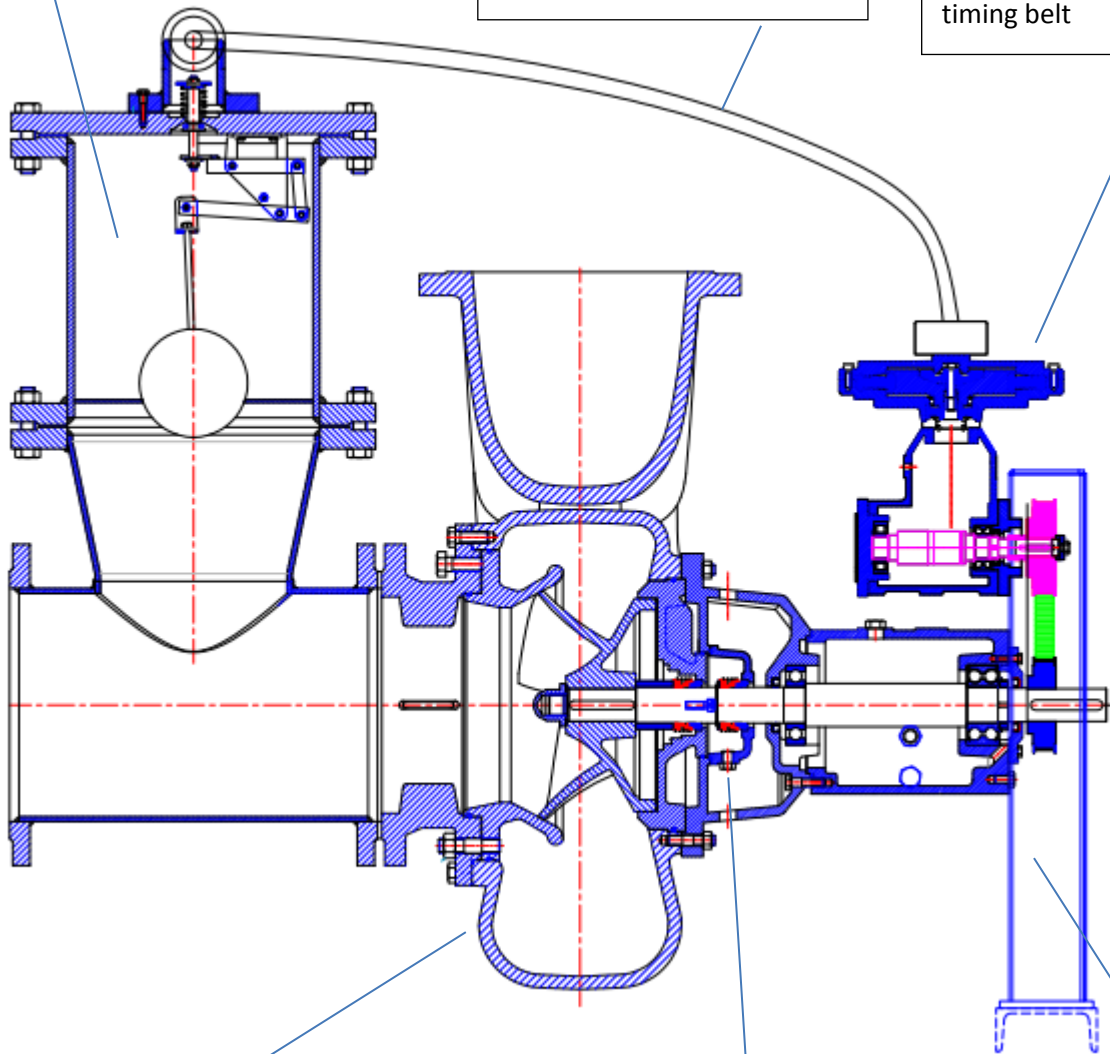

Rotatable body design according to installation status with modular foot structure

Special oil box design with double seal, allowing for dry running

Belt-Pulley safeguard cabinet



# ENDURO-PRO Series

Single Stage Horizontal Type Sewage and Wastewater Pumps

## Performance Curves



Mas Grup

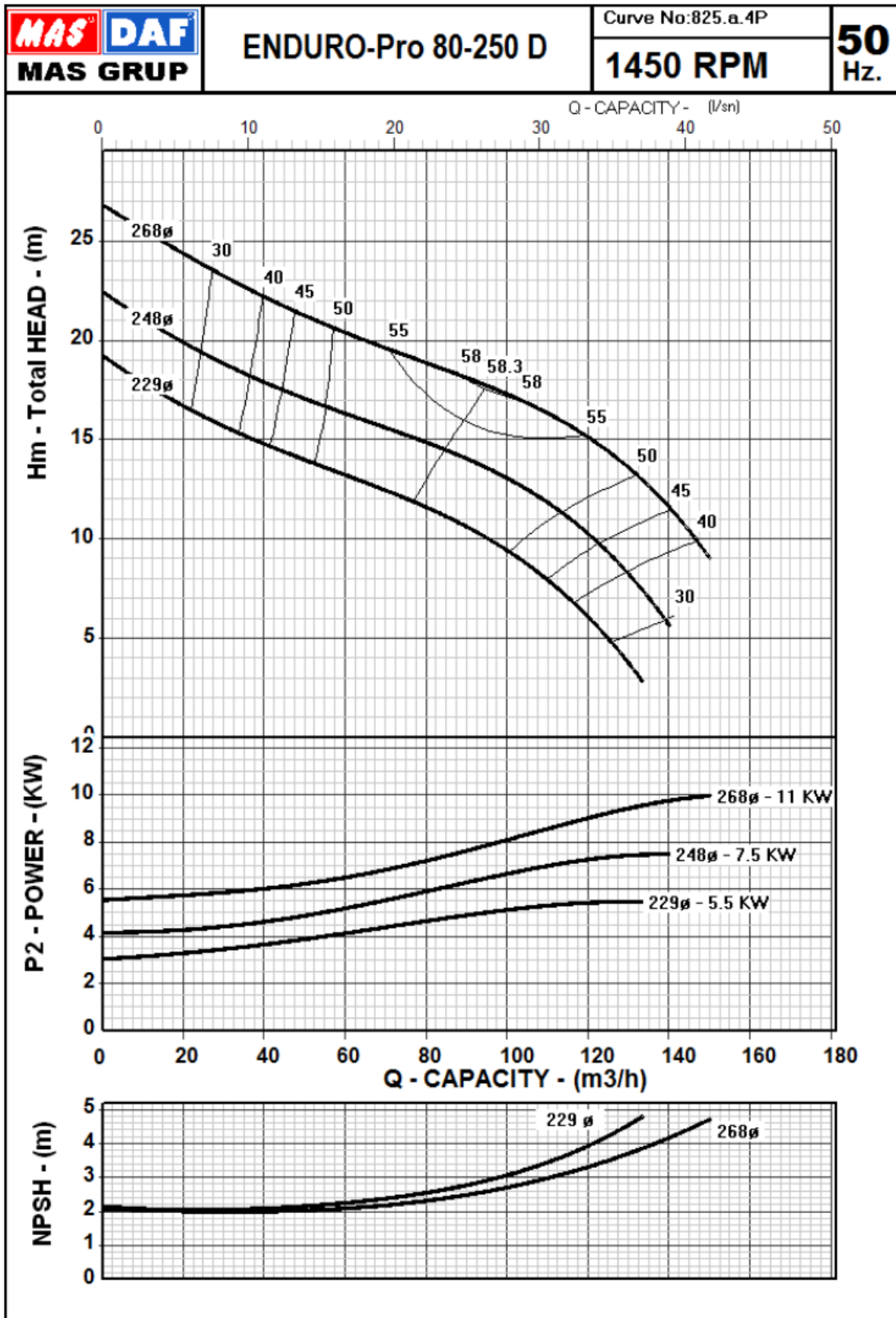



# ENDURO-PRO Series

Single Stage Horizontal Type Sewage and Wastewater Pumps

## Performance Curves



Mas Grup

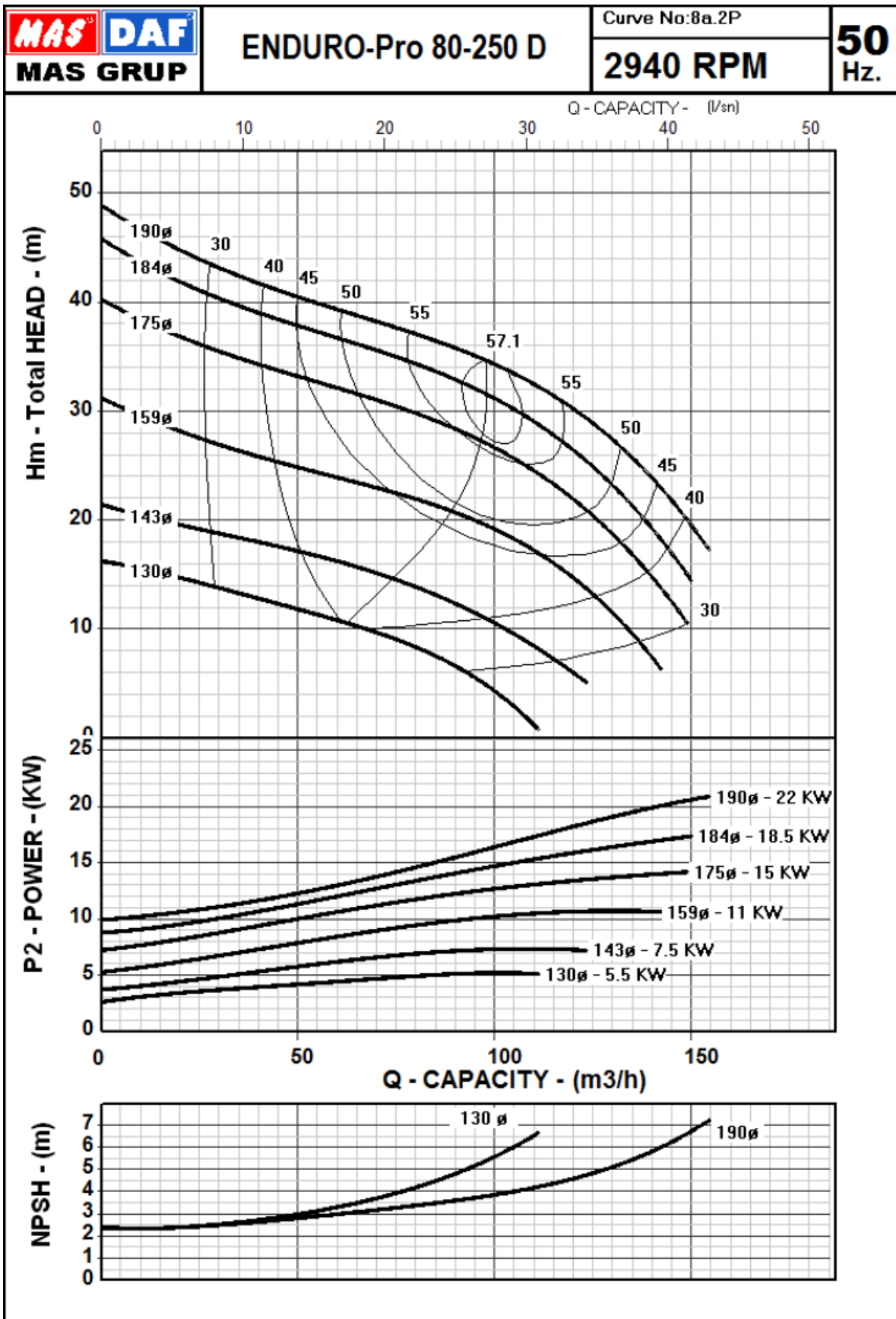

# ENDURO-PRO Series

Single Stage Horizontal Type Sewage and Wastewater Pumps

## Performance Curves



Mas Grup

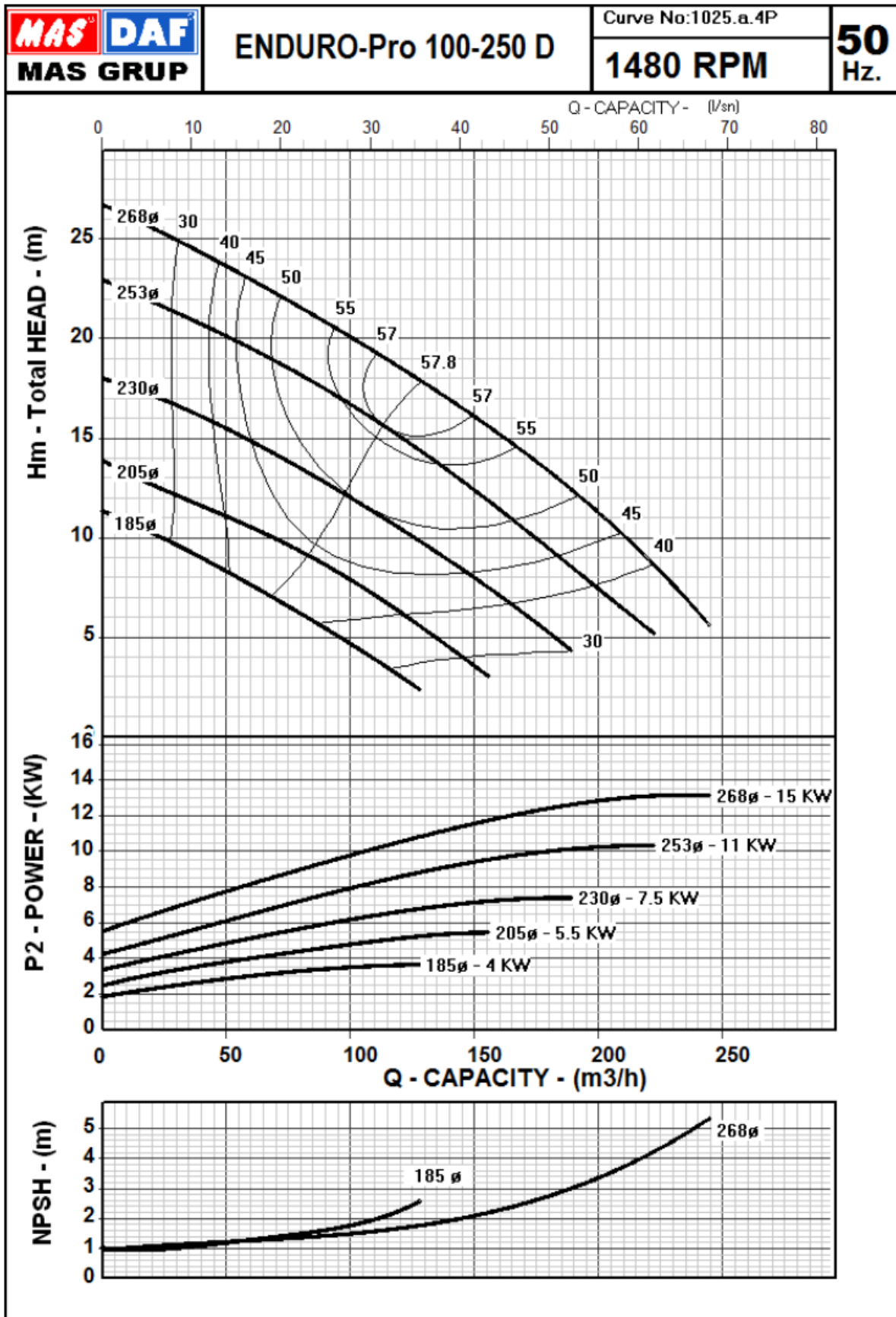

# ENDURO-PRO Series

Single Stage Horizontal Type Sewage and Wastewater Pumps

## Performance Curves



Mas Grup

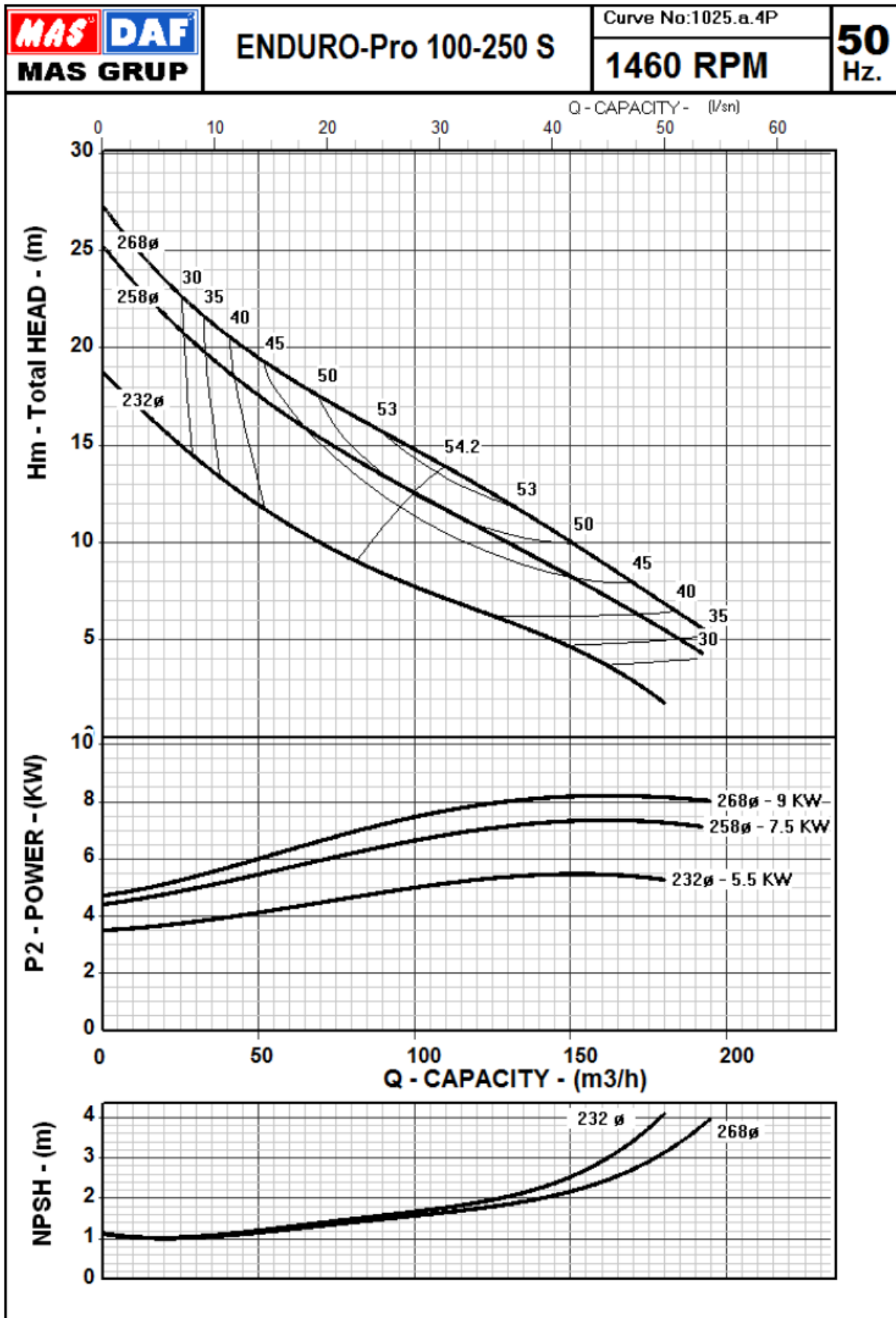

# ENDURO-PRO Series

Single Stage Horizontal Type Sewage and Wastewater Pumps

## Performance Curves



Mas Grup

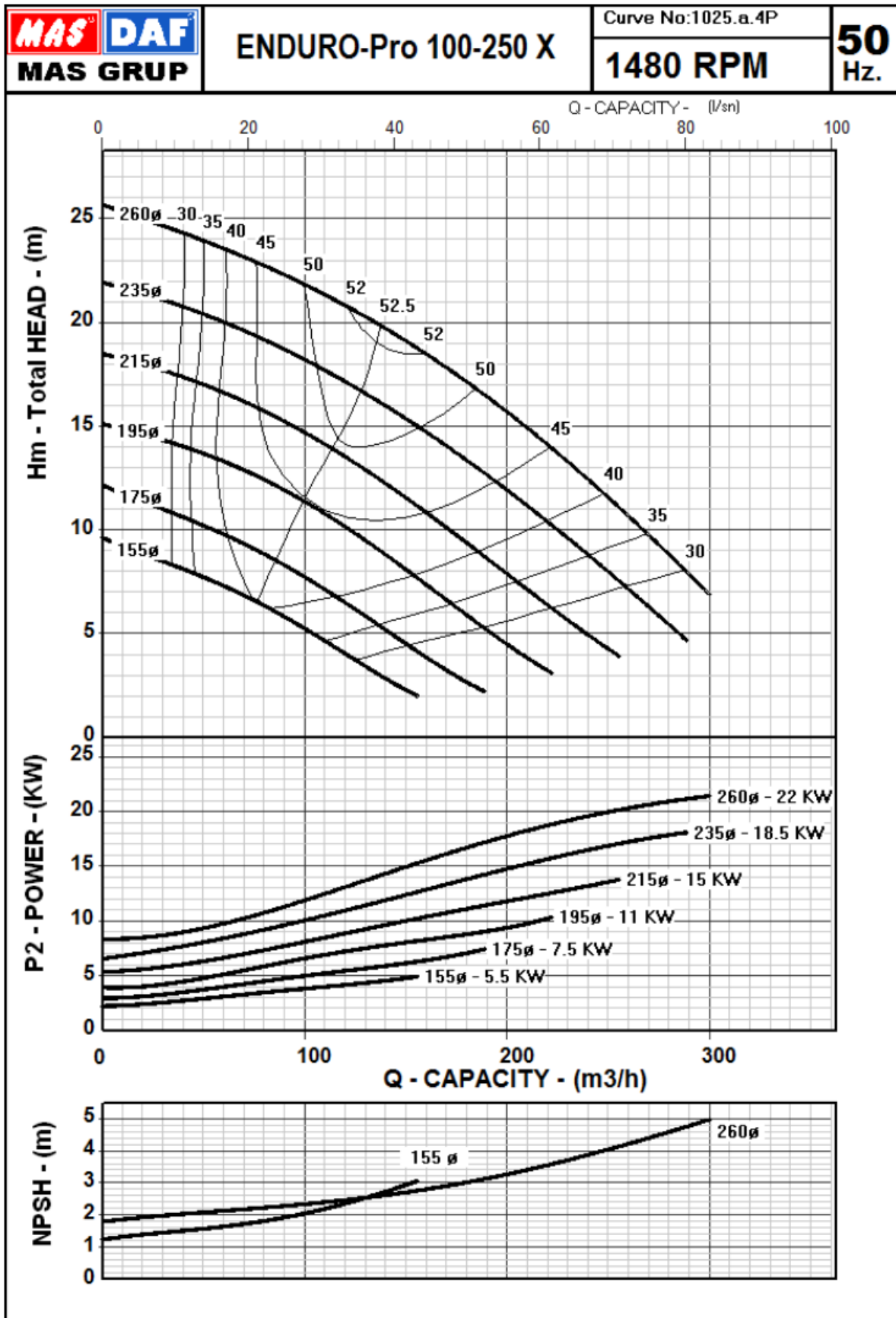

# ENDURO-PRO Series

Single Stage Horizontal Type Sewage and Wastewater Pumps

## Performance Curves



Mas Grup

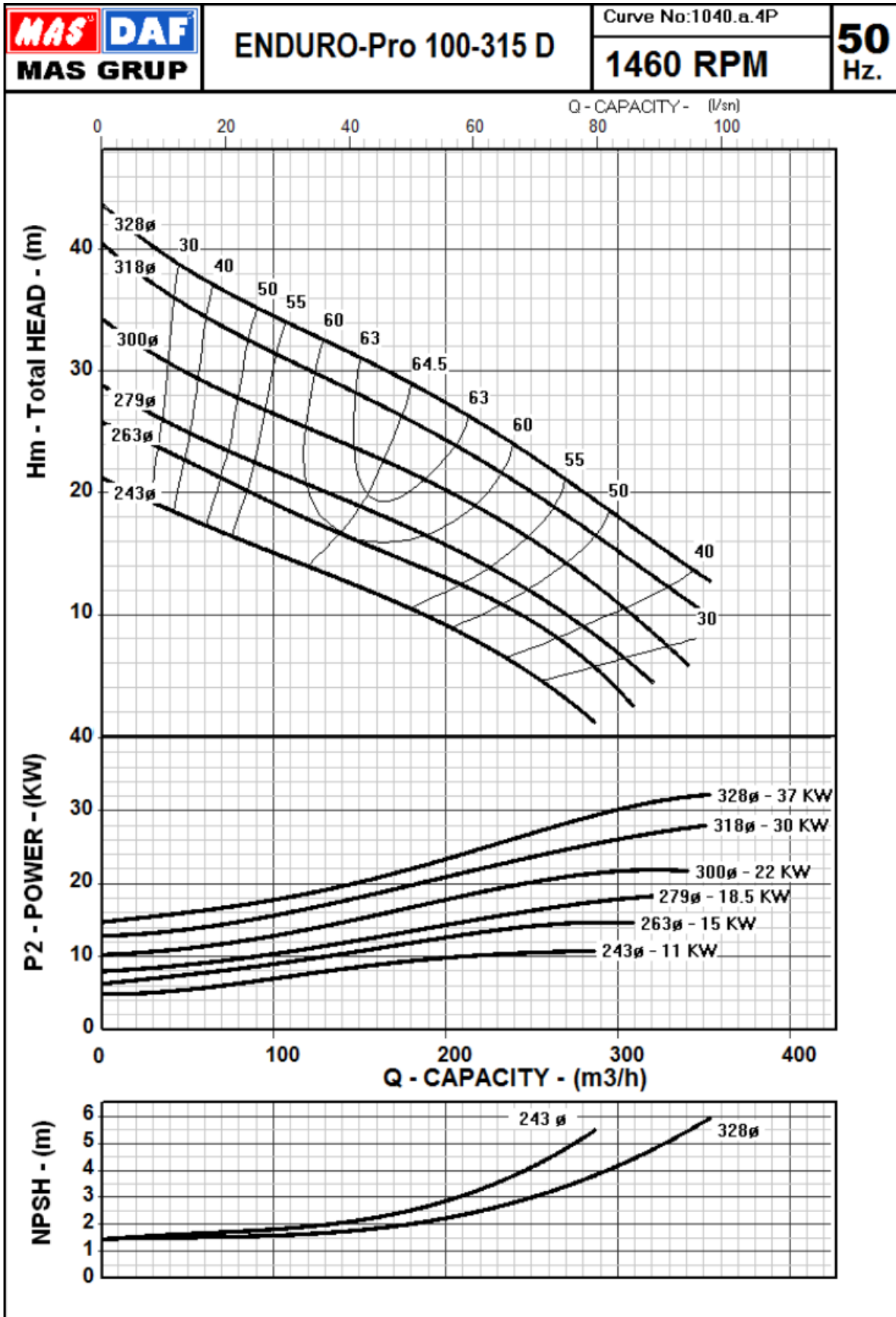

# ENDURO-PRO Series

Single Stage Horizontal Type Sewage and Wastewater Pumps

## Performance Curves



Mas Grup

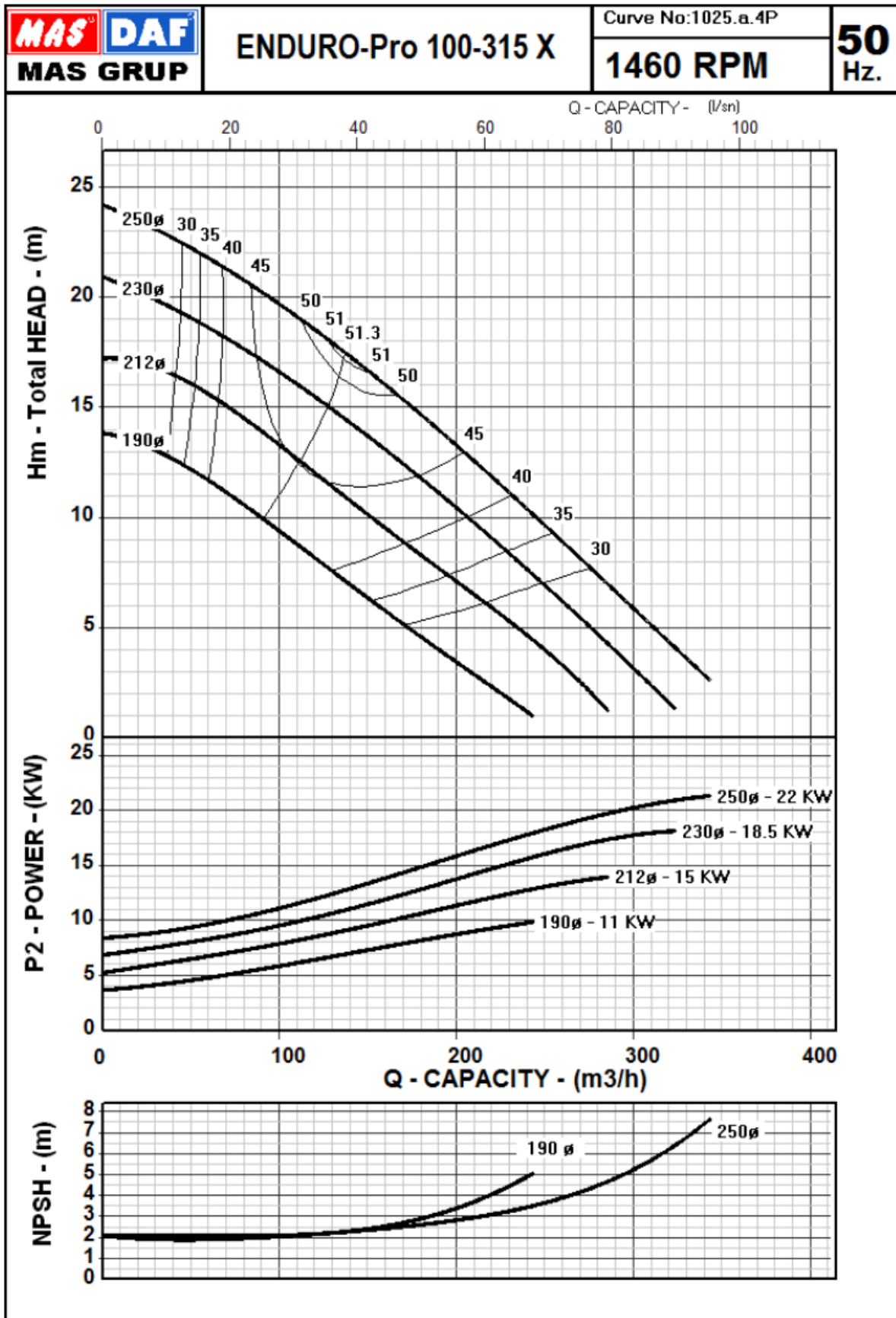



# ENDURO-PRO Series

Single Stage Horizontal Type Sewage and Wastewater Pumps

## Performance Curves



Mas Grup

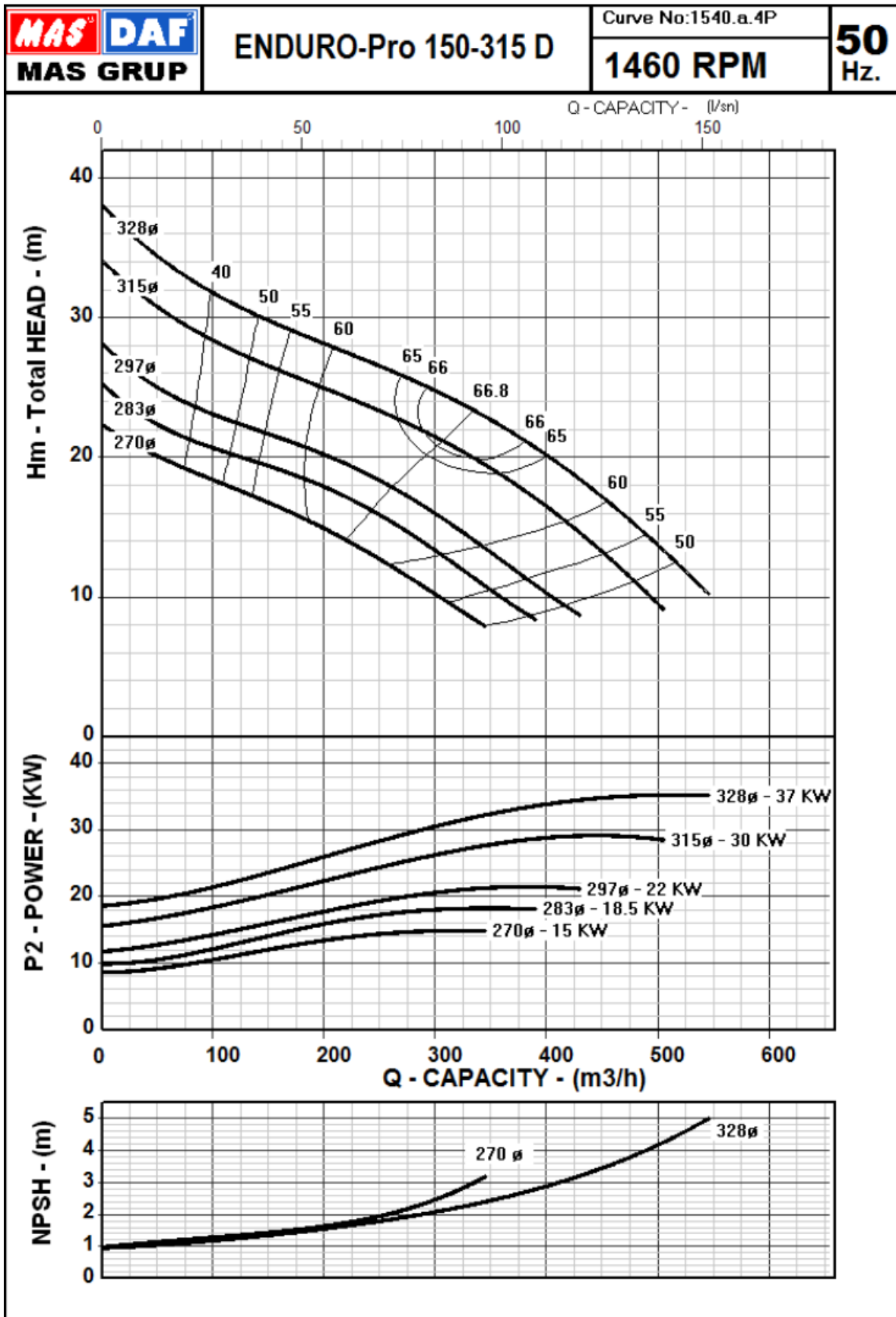



# ENDURO-PRO Series

Single Stage Horizontal Type Sewage and Wastewater Pumps

## Performance Curves



Mas Grup

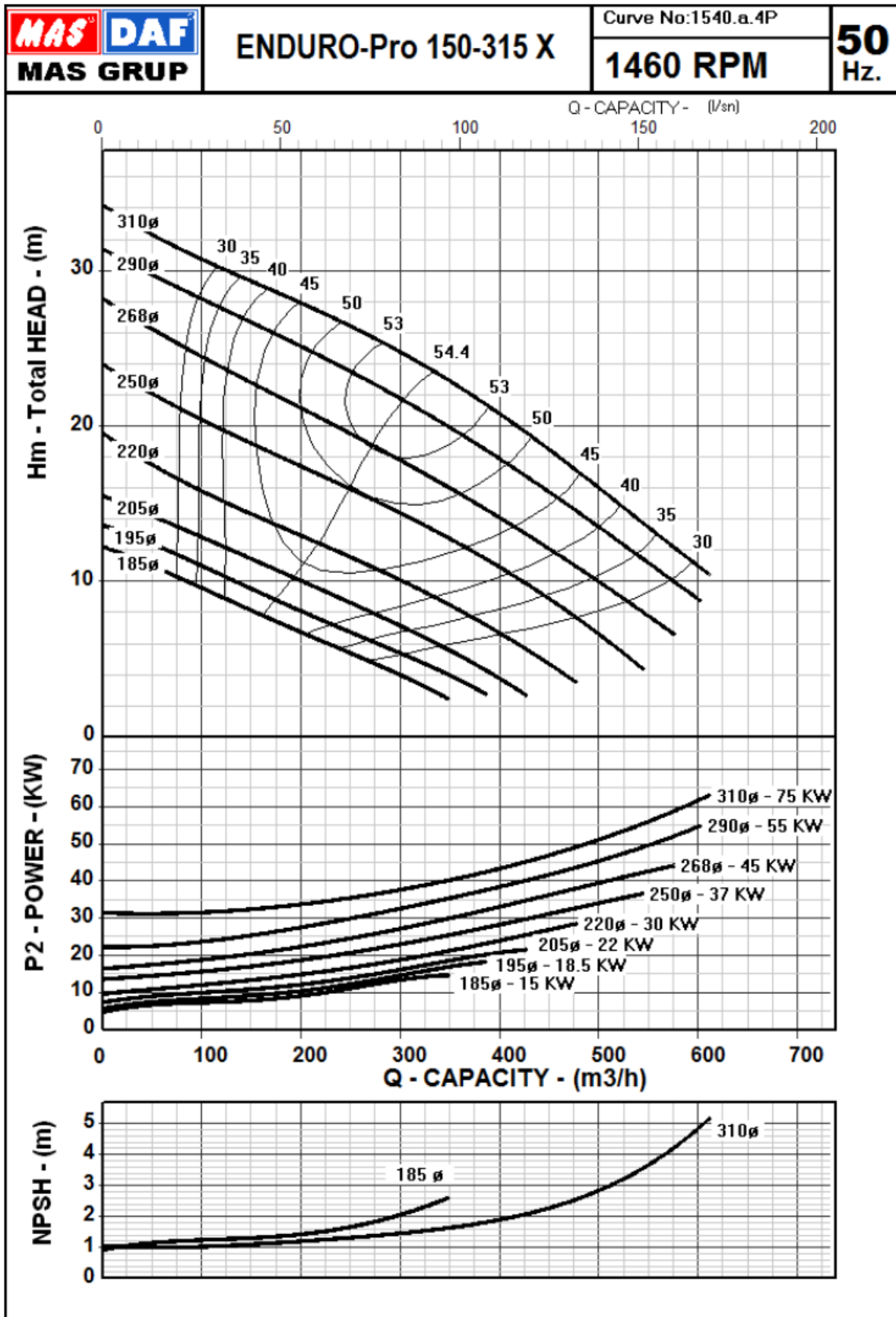

# ENDURO-PRO Series

Single Stage Horizontal Type Sewage and Wastewater Pumps

Drawing for Dismantling



Mas Grup

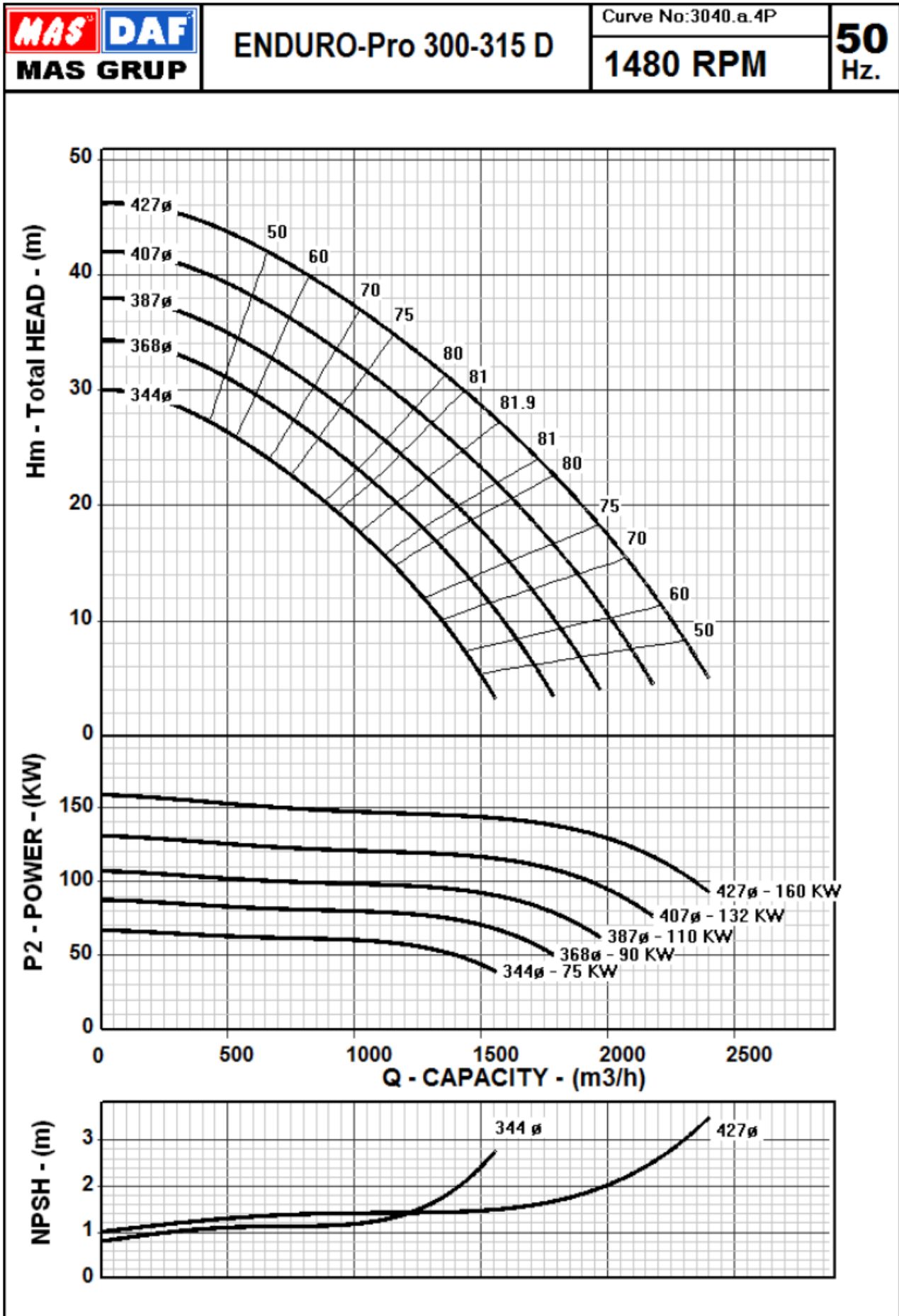

# ENDURO-PRO Series

Single Stage Horizontal Type Sewage and Wastewater Pumps

## Drawing for Dismantling



Mas Grup

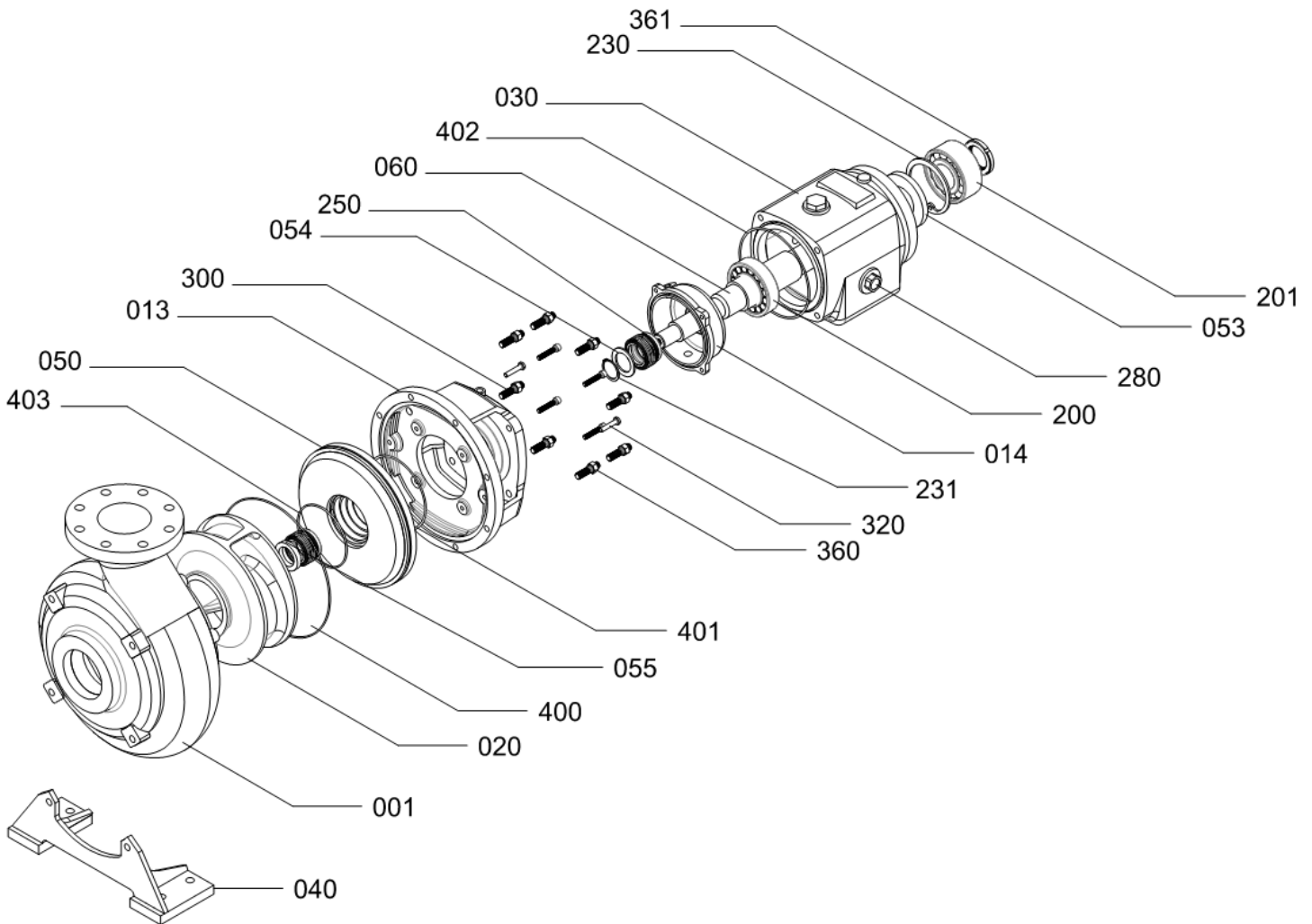

PART NO	PART NAME	PART NO	PART NAME	PART NO	PART NAME
01	Volute Casing	55	Mechanical Seal Sleeve	320	Bolt
13	Spacer	60	Shaft	360	Nut
14	Sealing Oil Bath	200	Bearing	361	Nut
20	Impeller	201	Bearing	400	O-Ring
30	Bearing Housing	230	Retaining Ring	401	O-Ring
40	Supporting Foot	231	Retaining Ring	402	O-Ring
50	Stuffing Box	250	Mechanical Seal	403	O-Ring
53	Bearing Sleeve	280	Oil Gauge		
54	Mechanical Seal Sleeve	300	Stud		



## Mas Grup

### Head Office / Center Service:

Aydınlı Mah. Birlik OSB. 1.No'lu Cadde No:17 Tuzla - İSTANBUL / TÜRKİYE  
Tel: +90 (216) 456 47 00 pbx Fax: +90 (216) 455 14 24

### Ankara Regional Directorate:

Cevizlidere Caddesi 7. Sokak No:2/7 Balgat - ANKARA / TÜRKİYE  
Tel: +90 (312) 472 81 60-67 Fax: +90 (312) 472 82 51

### Factory:

1. Organize Sanayi Bölgesi Parsel 249/5 Beyköy - DÜZCE / TÜRKİYE  
Tel: +90 (380) 553 73 88 Fax: +90 (380) 553 71 29